

T-7311 6" DA SANDER T-7311W5 5" DA SANDER T-7311SL W/ SAFETY LEVER

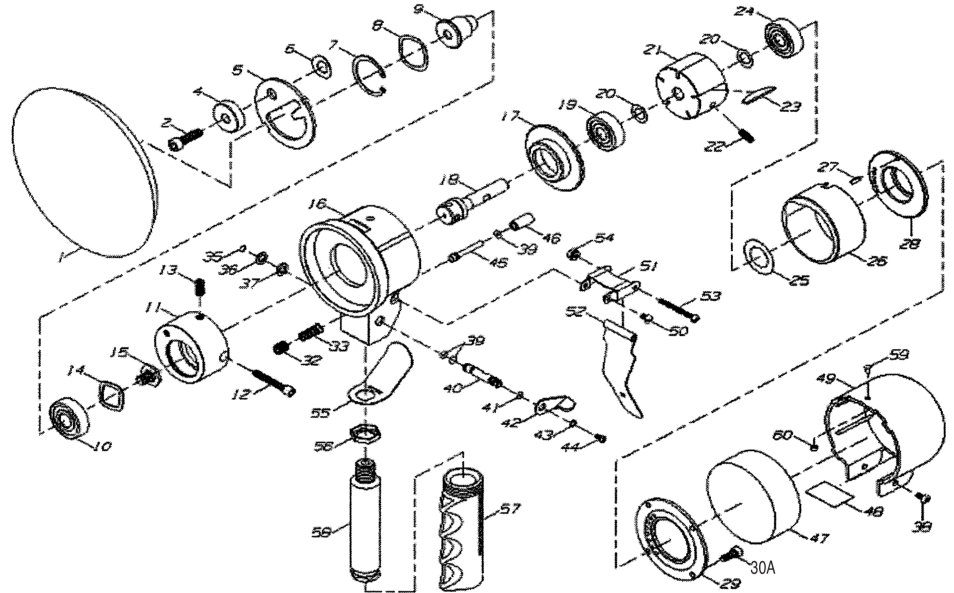

**OILING INSTRUCTIONS:
OIL AFTER EACH USE
WITH A FEW DROPS OF
AIRTOOL OIL THROUGH
THE AIR INLET. RUN FOR
1 SECOND TO COAT ALL
INTERNAL PARTS.**



USE 90 PSI MAXIMUM

REF #	PART #	DESCRIPTION	QTY	REF #	PART #	DESCRIPTION	QTY
1	T-7415	5" SANDING PAD (T-7311W5)	11	30A	73130A	SCREW & WASHER	4
	T-7416	6" SANDING PAD (T-7311)	1	32	731132	CAP SCREW	1
2	731102	CAP SCEW	1	33	731133	THROTTLE SPRING	1
4	731104	BALANCE NUT	1	35	731135	RETAINING RING	1
5	731105	DRIVE WASHER	1	36	731136	PLATE WASHER	1
6	731106	WAVE WASHER	1	37	731137	RUBBER WASHER	1
7	731107	RETAINING RING	1	38	731138	SCREW	2
8	731108	WAVE WASHER	1	39	731139	O-RING	3
9	731109	PAD MOUNTING SHAFT	1	40	731140	REGULATOR	1
10	731110	BEARING	1	41	731141	O-RING	1
11	731111	RANDOM BALANCER BODY	1	42	731142	REGULATOR SWITCH	1
12	731112	SCREW	1	43	731143	LOCK WASHER	1
13	731113	SCREW	1	44	731144	SCREW	1
14	731114	WAVE WASHER	1	45	731145	PUSH ROD	1
15	731115	SCREW	1	46	731146	VALVE BODY	1
16	731116	BODY	1	47	731147	MUFFLER	1
17	731117	FRONT PLATE	1	48	731148	MUFFLER ELEMENT	1
18	731118	ROTOR SHAFT	1	49	731149	MOTOR COVER	1
19	731119	BEARING	1	50	731150	SCREW	2
20	731120	SHIM	4	51	731151	LEVER BRACKET	1
21	731121	ROTOR	1	52	731152	LEVER BOOSTER	1
22	731122	SET SCREW	1		731152SL	SAFETY LEVER (OPTIONAL)	
23	731123	ROTOR BLADES (SET OF 5)	1set	53	731153	BOLT	1
24	731124	BEARING	1	54	731154	NUT	1
25	731125	BEARING SHIELD	1	55	731155	VALVE LEVER	1
26	731126	CYLINDER	1	56	731156	LEVER JAM NUT	1
27	731127	PIN	1	57	731157	PLASTIC FRIP	1
28	731128	REAR PLATE	1	58	731158	HANDLE	1
29	731129	ROTOR FIXING COVER	1				

505 N. Railroad Ave. 33435
P.O. Box 1117 33425
Boynton Beach, FL

SEE MORE OF OUR CATALOG AT
www.taylorpneumatic.com
OCTOBER 2020 / ALL RIGHTS RESERVED / COPYRIGHT 2020

Ph. (561)732-1111
Fax. (561)731-4412
Toll Free (800) 805-8665